

# The Chronology of the Divine Plan

- Plan to show that Second Volume chronology is correct, except that there needs to be three minor tweaks. They do not affect any harvest time chronology on this end of age!
- We also hope that we are able to give a more complete presentation, similar to what the new chronology gave, at a future time from this one.
- What looks impressive with David's chronology is deceptive. There are two triple parallels in our chronology that we could show that are more impressive than David's double parallels which he showed on the first night of his presentation. He showed a chronology diagram which showed that Jeremiah was parallel to Pastor Russell and that to him was presented as proof that his chronology was correct.
- To counter that we have a triple parallel that shows Jeremiah's 40 years was parallel to Christ and then to Pastor Russell.

- We also have another triple parallel that has Josiah, Christ and Pastor Russell parallel to each other.— Can't show either of those diagrams because of time.
- BC to AD correction we agree with David on— there is only a zero point & not a zero year--- that fixes the 7 times of the Gentile Times. The date has to be Oct 607 and not 606.
- $(-606.25 + 2520 = 1913.75 \text{ AD})$
- 19 years removed in time of Babylon and 19 years added just before Judges. Total change = zero on this end of the age.

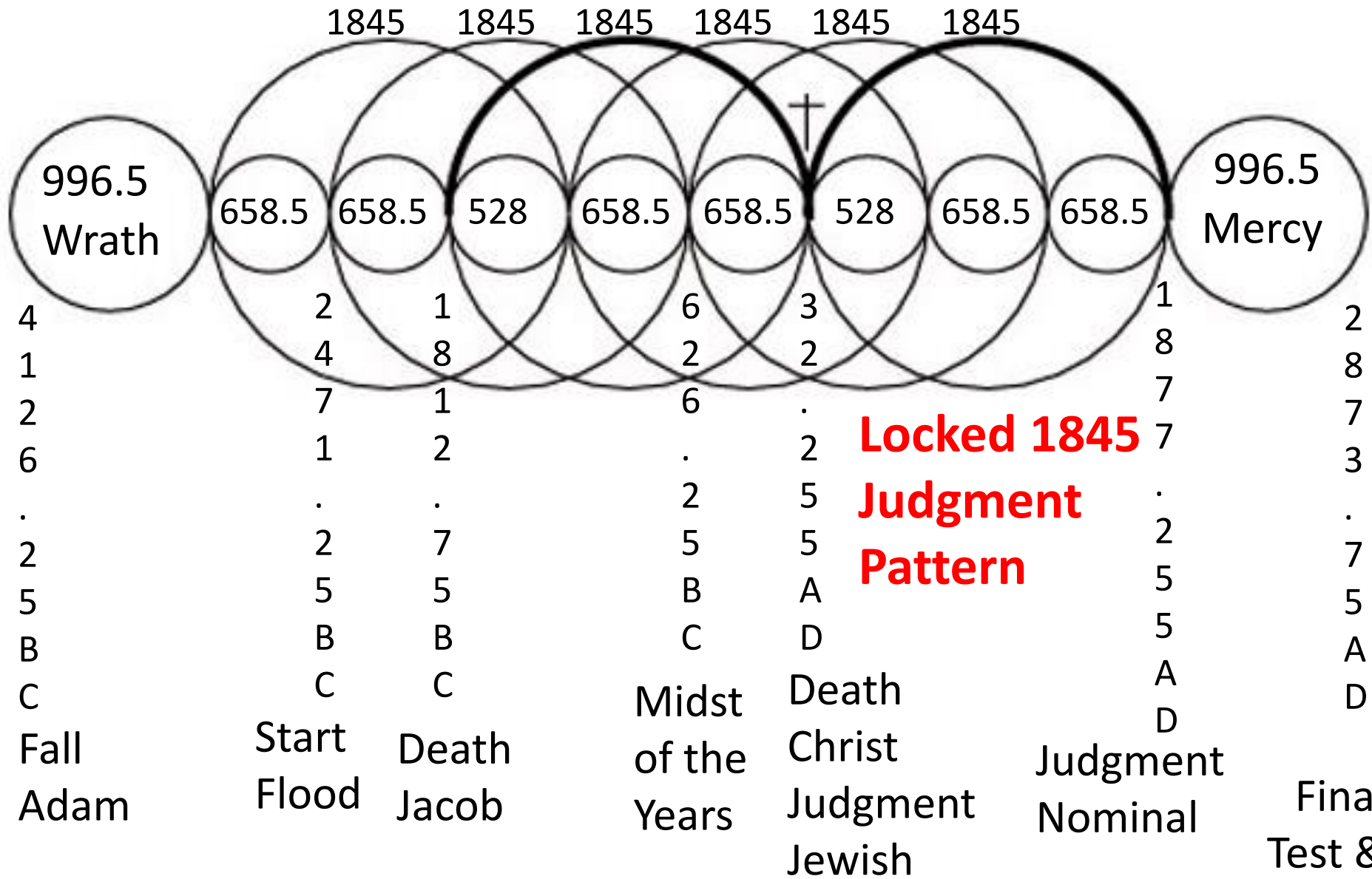

**Wheels Within Wheels 4 Cherubim?**

Restoration Complete

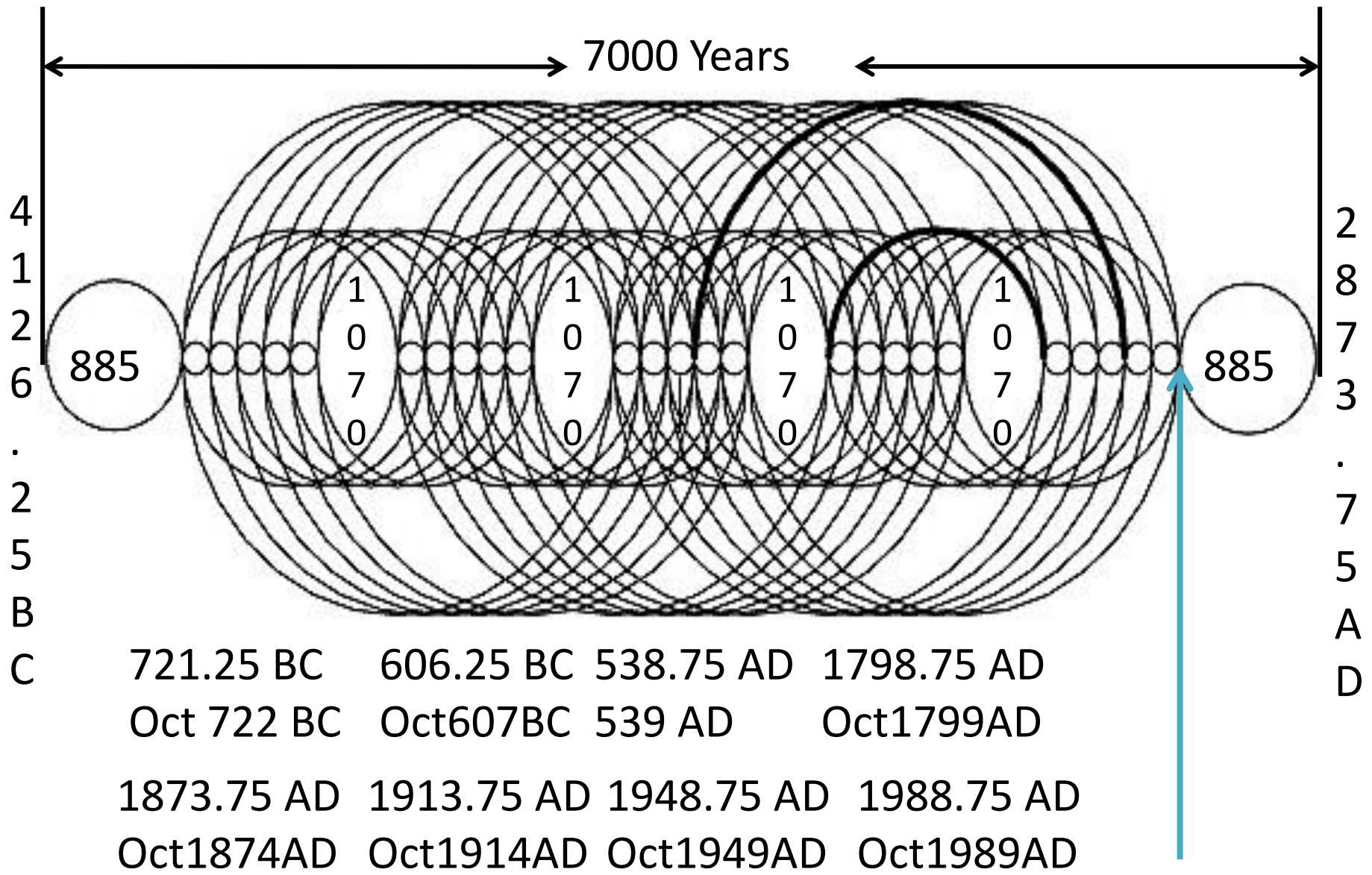

Birth  
Christ  
1.25 BC

Return  
Lord  
1873.75 AD

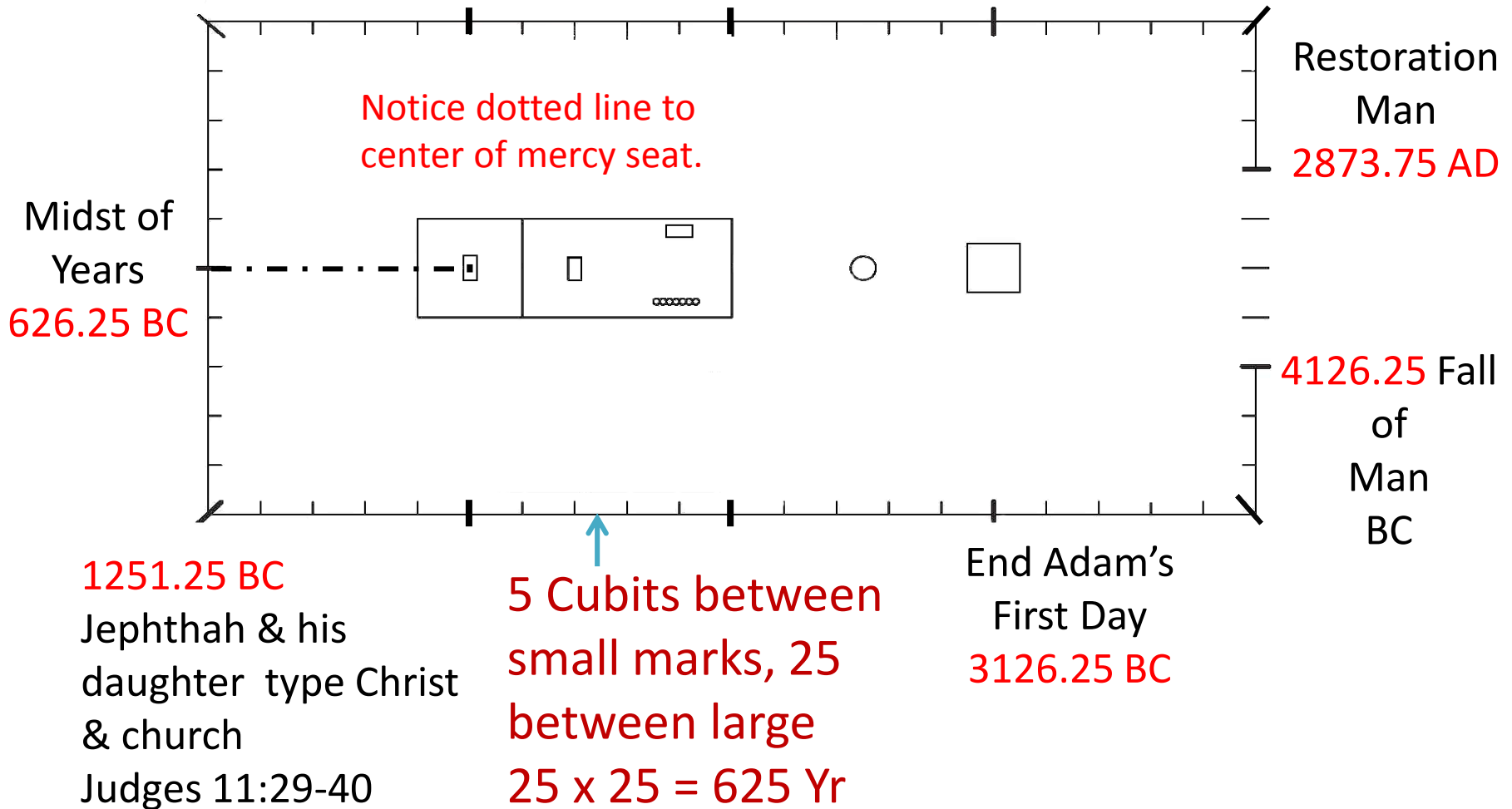

50 x 50 = 2500 Chronology Locked

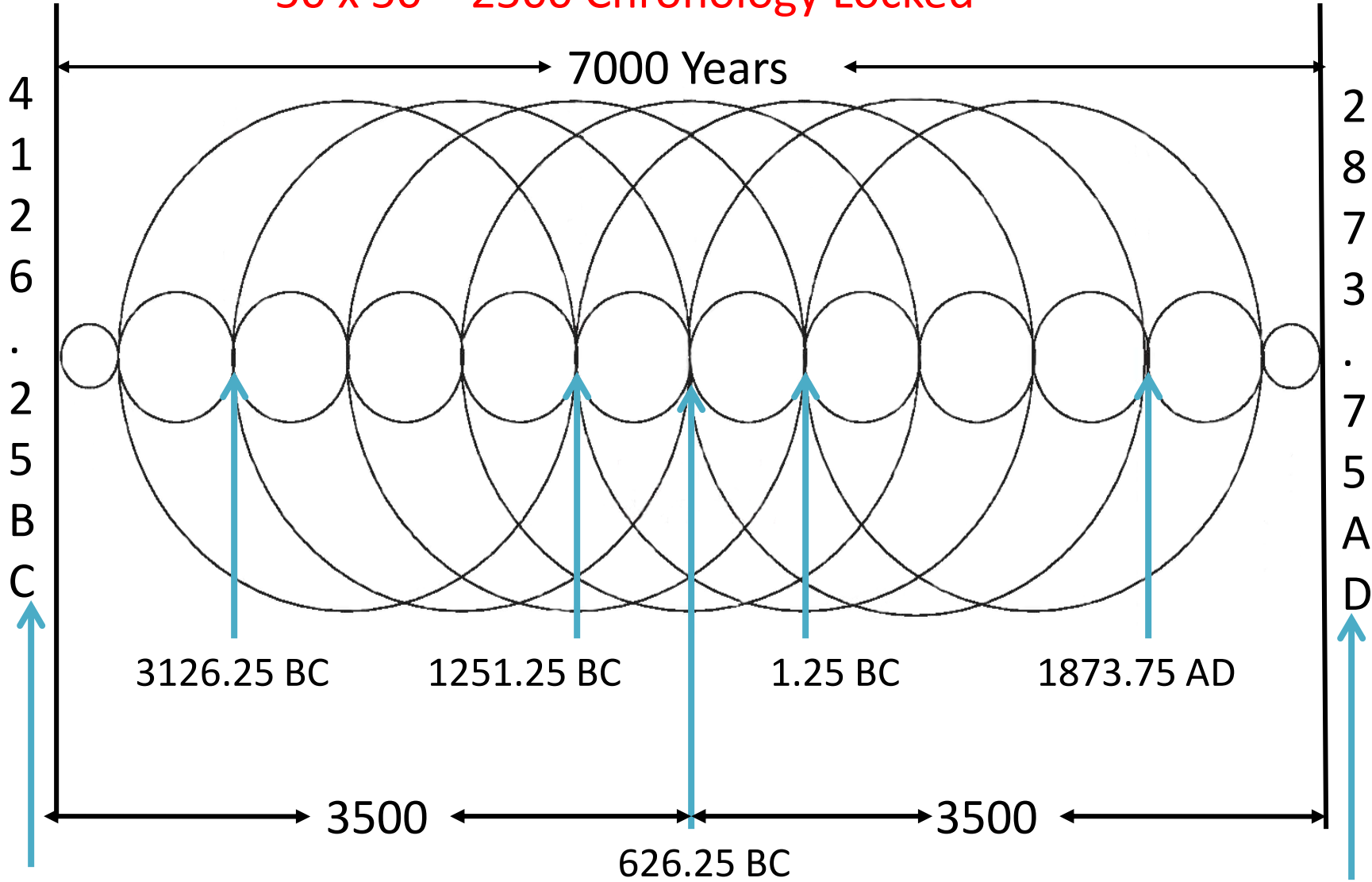

Wrath

Seven Important Dates

Mercy

1. The Exodus and wilderness period 40 years
2. The conquering and then dividing of the land 6 years Nub 10:11-13 Joshua 14:6-10.
3. We add 19 years for Joshua and the elders here, just after the dividing of the land. See note 8 for the possibility that this is part of the 450 and Samuel's 20 years as judge is not. Jephthah's 300 years is referring back to the dividing of the land See note 3.
4. 1<sup>st</sup> Servitude (Chushan or Mesopotamian) 8 years. Judges 3:8
5. Rest by Othaniel 40 years. Judges 3:9-11
6. 2<sup>nd</sup> Servitude (Eglon or Moab) 18 years. Judges 3:14 Eglon is same as Ammonites. See notes.
7. Rest by Ehud 80 years. Judges 3:15, 30 Jabin, Barak and Deborah included in this 80 years. Shamgar included in 3<sup>rd</sup> Servitude Judges 3:31, Judges 4:1- No time recorded.
8. Rest after Barak and Deborah is 40 years. Judges 4:4, 5:31 See the alternate count possibility.
9. 4<sup>th</sup> Servitude (Midian) 7 years Judges 6:1
10. Rest by Gideon 40 years. Judges 6:11-13, 8:28
11. The usurpation of Abimelech 3 years. Judges 9:22
12. The Judgeship of Tola 23 years. Judges 10:1-2
13. The Judgeship of Jair 22 years. Judges 10:3, 5 The 300 years counts from the dividing of the land back up to the beginning of the 18 years in this time area, which is the attempt by Amon 300 years later to recover their land. Jephthah is looking back at the first year that they had attacked, saying why did they wait 300 years before trying to recover their land. See note 3. See note 9 for a scripture, which proves this is a new oppression.
14. **Start of first year of servitude to Ammon** ←
15. 5<sup>th</sup> Servitude (Ammon) 18 years. Judges 10:8 Jephthah defeats them in 18<sup>th</sup> yr then becomes judge.
16. Jephthah 6 years. Judges 12:7. He becomes a judge after the defeat of Ammon, see note below.
17. The Judgeship of Ibzan 7 years. Judges 12:7
18. The Judgeship of Elon 10 years. Judges 12:10-11
19. The Judgeship of Abdon 8 years. Judges 12:12-15
20. 6<sup>th</sup> Servitude (Philistines) 40 years. Jud 13:1
21. 20-year judgeship of Sampson is not included in the Philistine oppression. Jud 15:20, 16:30, 31 See note 5.
22. Judgeship of Eli 40 years, 1 Sam 4:12-18.
23. Eli Saul connection- Judgeship of Samuel to Saul = 20. 1Sam 8:5, Acts 13:20-21. Ark remained in Kirjath-Jearim 20 years, 1Sam 7:2. We know that Saul brought the ark to himself at the coronation. Samuel continues as Prophet during Saul's kingship, but he is no longer judge. See notes 3, 8.
24. Reign of Saul 40 years.
25. Reign of David 40 years
26. Reign of Solomon to fourth year. Count 3 years. See note 6.

3  
0  
Y  
E  
A  
R  
S

4  
5  
0  
Y  
E  
A  
R  
S

---

Total of 598 years from Exodus to the temple.



## The “Lo-Ammi” Periods 50.VII(II) Page 70

When Israel was regarded by Jehovah as “LO-Ammi” Not my People (Hos 1:8, 2:1) then Jehovah dealt with them on a different principle in recording time. During these periods their national history years are omitted from the years of the worlds lifetime. When they were LO\_Ammi, the events recorded in the scriptures, were recorded according to a reckoning we have termed Anno Dei (in God’s year) and not according to Anno Mundi (in the year of the world) reckoning. Here is the key to understanding of Biblical Chronology; and it will be found when rightly applied, to unlock many “difficulties” and to remove many supposed discrepancies “between passages in the scriptures.

### **Total time not in control of the land**

1. Conquering of the land  $1 + 6 = 7$  years. 1 year on land East Jordan.
2. Chushan Oppression 8 years
3. Eglan Oppression 18
4. Jabin Oppression 20
5. Midian Oppression 7
6. Ammon Oppression 18
7. Philistine Oppression 40

---

### **Total time not in control of the land 118**

598 - 118 = 480 years. See 1K 6:1. See the comments in the notes following this section.

Is this calculation from God or from the scribes?  
What difference does it make?

	Loss of Ten Tribes- Western Leg-Papacy		Loss of Two Tribes- Eastern Leg-Islam	
	Assyria attacks the 10 tribes. Siege of Symaria for 2-3 yr.	724.25 BC		
	10 Tribes Destroyed by Assyria Judah & Temple remains.	721.25 BC		
		717.75 BC		
		609.75	Assyria conquered by Babylon	609.75
		606.25 BC	Neb crosses Euphrates conquering and then started to take control of Judah shortly after this time	606.25 BC Oct 607 BC
		602.75 BC	Neb completes conquest of Palestine, becomes head of gold.	602.75 BC
			Vision of future given Dan10-12	534.75 BC
			Last year of Cyrus	531.25 BC
				527.75 BC
		535.25 AD		
	Papacy gets involved with civil power.	538.75 AD Oct 539 AD	Military force is used at Ravenna to put down Arians, non-trins.	
		542.25 AD		
			Begin Moslem conquests.	650.25 AD
			Arabs conquered Armenia	653.75 AD
			Sunni Moslems get dominate civil power in Palestine.	657.25 AD
		1795.25 AD		
	Papacy loses civil power	1798.75 AD Oct 1799		
	Spiritual restoration begins.	1828.25 AD		
	End 6000. Start of second presence. Begin 40-year harvest.	1873.75 AD	Come out of her my people!	
	Judgement spiritual house.	1877.25 AD		
		1910.25 AD	Agadir crisis. Nations prepare war	1910.25 AD
	End 40-year harvest.	1913.75 AD	Nations involved with Papacy begin to destroy themselves.	1913.75 AD Oct 1914
	1917 Balfour declaration. A Jewish state advocated	1917.25 AD April 1918	Collapse of Turkish resistance in Palestine in 1918. Islamic Arabs no longer in control of Palestine.	1917.25AD
			Start war of independence. Israel invaded in May 1948. War ends 1949. Restoration of the nation.	1947.25 AD
	2300 years from Alexander the Great 334 BC.	1966.25 AD	Jerusalem restored in June 1967 AD, Dan 8:14.	1966.25 AD
	Berlin wall and USSR falls!			1988.75 AD Oct 1989
	Palestinians admitted that Israel has the right to exist. Gave national rights to Israel for financial and statehood help???	1992.25 AD April 1993	Oslo declaration of principles on interim self-government signed by Israel and the P.O. Vatican recognizes Israel.	1992.25 AD
	End of a 7-year time period? Old city gate opened to Arab quarter		Oslo to be implemented this yr	1995.75

Note - The dates that have a gray background are the interest points from the 1260 and 2520 year circle patterns. See the Divine Plan and its Chronology, page 18.

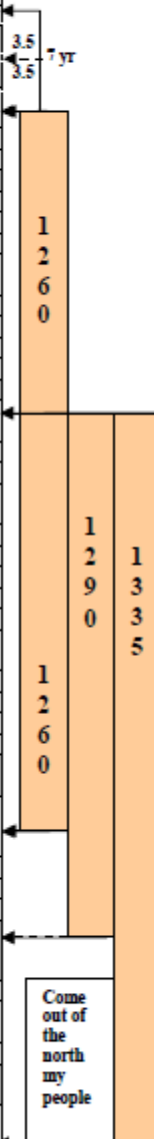
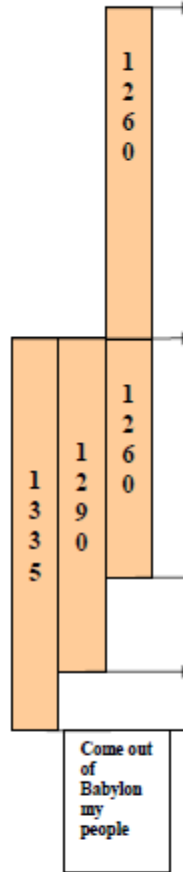

Come out of Babylon my people

Come out of the north my people

AN EXPANSION OF THE 1260, 1290, 1335 CHRONOLOGY AND THE DOUBLE APPLICATION

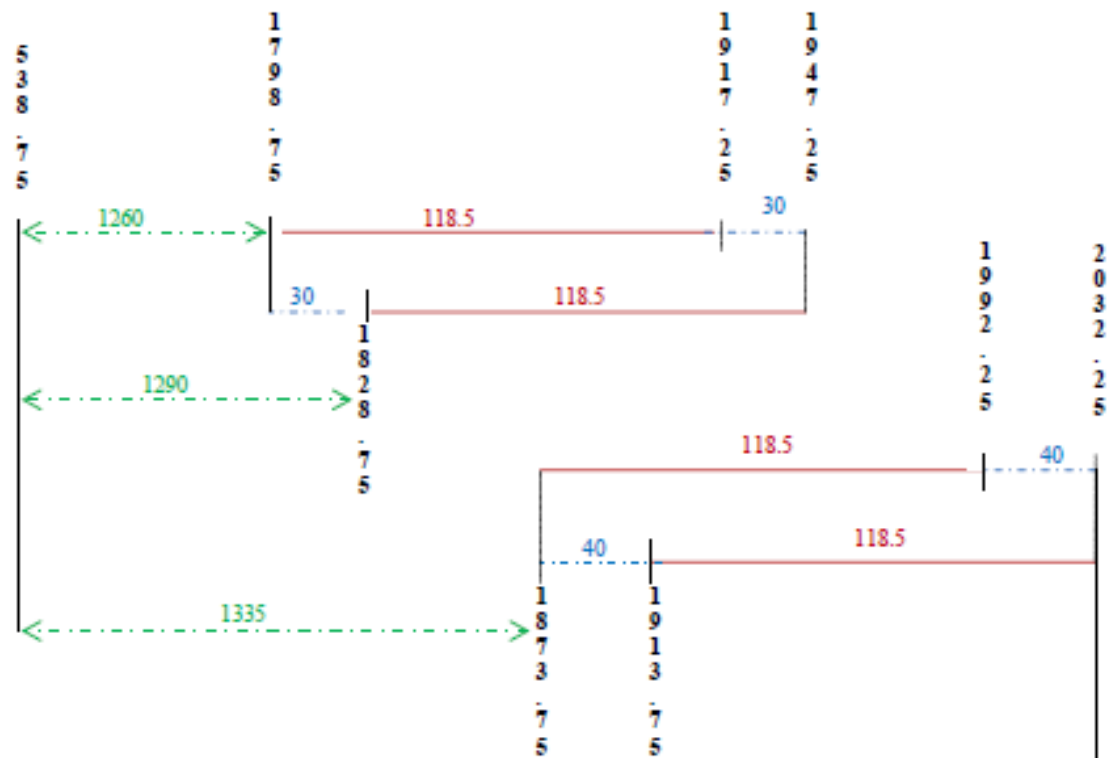

Hos 6:2 "He will revive us after two days;  
 He will raise us up on the third day, That  
 we may live before Him. NASU  
 After 2000 years?

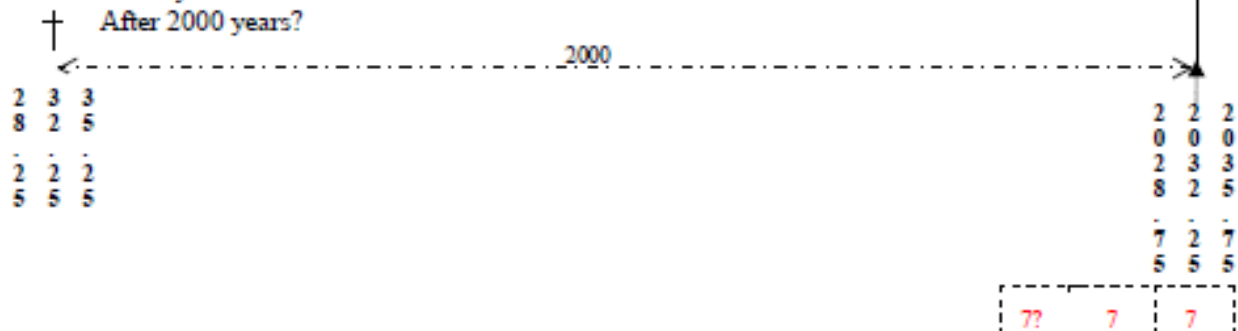

# 2300 DAYS

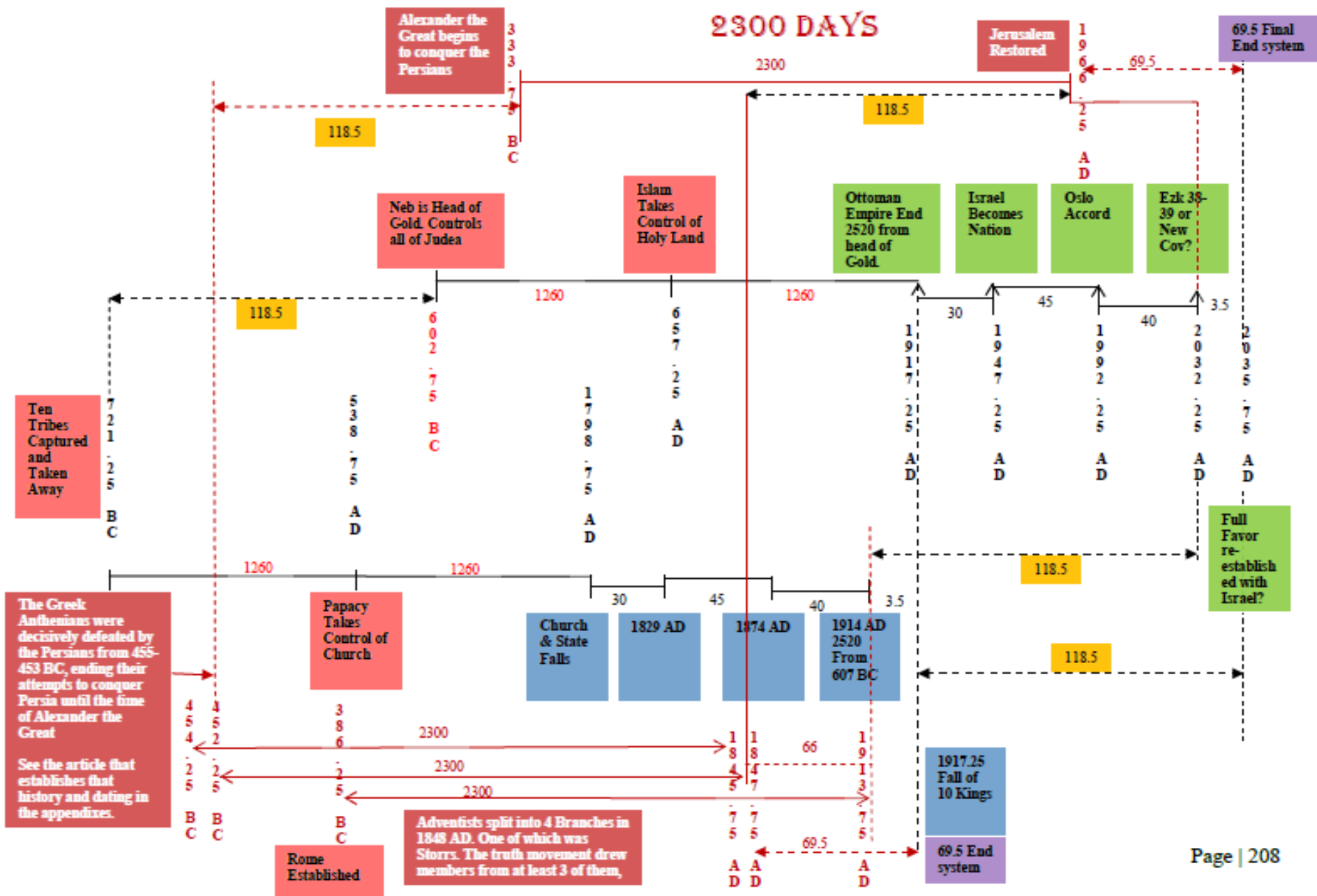



2 Chr 26:3 Sixteen years old was Uzziah when he began to reign, and he reigned fifty and two years in Jerusalem. His mother's name also was Jecoliah of Jerusalem. (KJV)

The 52 years counts from here, but he is only 5 years old here so his legal reign starts 11 years later when he is 16 years old. 2K15:1-2.

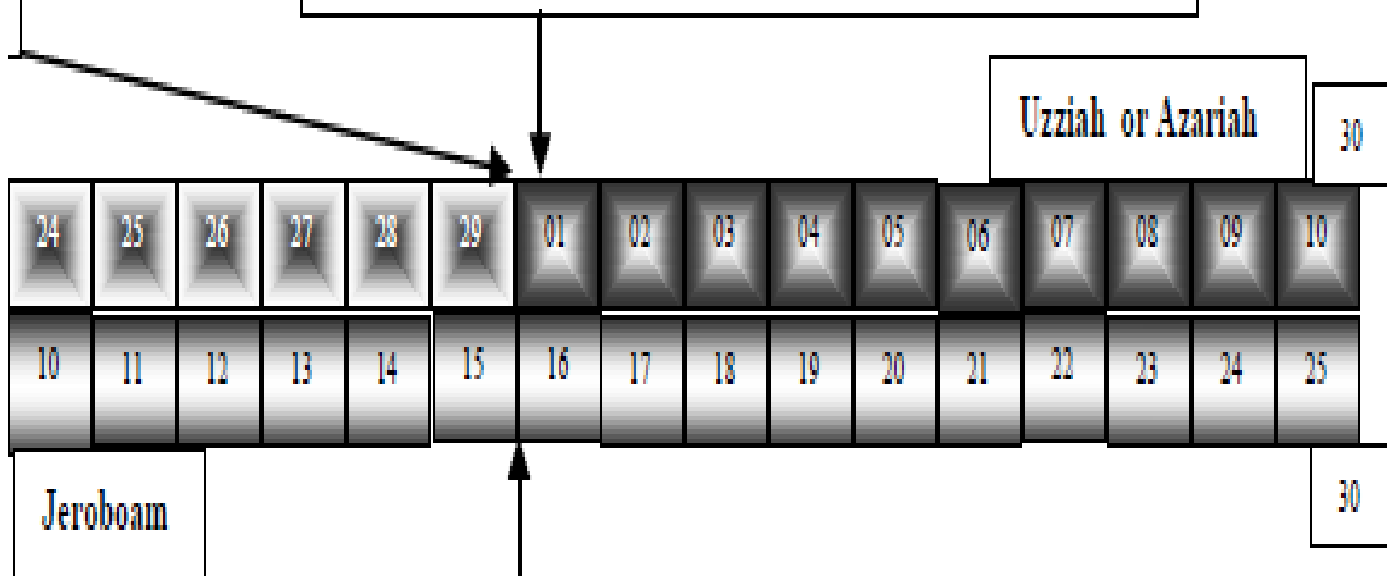

The date of 5000 BC is the correct date of the...

7  
9  
9  
·  
2  
5  
B  
C

II Ki 15:1-2 (1 In the twenty and seventh year of Jeroboam king of Israel began Azariah son of Amaziah king of Judah to reign.  
2 Sixteen years old was he when he began to reign, and he reigned two and fifty years in Jerusalem. And his mother's name was Jecholiah of Jerusalem. (KJV)

Note 5

Judah

Uzziah or Azariah

11	12	13	14	15	16	17	18	19	20	21
26	27	28	29	30	31	32	33	34	35	36

Israel

Jeroboam



24	25	26	27	28	29	30	31	32	33	34	35	36	37	38	39	40
39	41	01	02	03	04	05	06	07	08	09	10	11	12			01

Zechariah

Note 6

30

because the bible does not mention any  
 zations for four other kings linking to  
 for each king.  
 t appears unlikely.  
 ing and in anarchy. That is also unlikely.

II Ki 15:8 In the thirty and eighth year of  
 Azariah king of Judah did Zachariah the son of  
 Jeroboam reign over Israel in Samaria six  
 months. II Ki 15:13 Shallum the son of Jabesh  
 began to reign in the nine and thirtieth year of  
 Uzziah king of Judah; and he reigned a full  
 month in Samaria. Note-We count 1 yr for

II Ki 15:17 In the  
 nine and  
 thirtieth year of  
 Azariah king of

(4) Another more likely explanation is that similar to Uzziah of Judah, Zachariah was 4 and too young to reign until the 38<sup>th</sup> year of Uzziah and counselors would have been covering for him during the first 12 years. Because of that the scribes must have neglected to give either king credit for the time, and that points to his being too young as being the correct explanation.

**Zachariah had to have been on the throne or at least heir during that time because of God's promise: II Ki 15:11-12 (11** Everything else that Zechariah did is recorded in The History of the Kings of Israel.<sup>12</sup> So the promise was fulfilled which the LORD had made to King Jehu: **"Your descendants down to the fourth generation will be kings of Israel."** Thus one or the other or both had to be sitting on the throne during that time to satisfy God's promise!

24	25	26	27	28	29	30	31	32	33	34	35	36	37	38	39	40
39	41	01	02	03	04	05	06	07	08	09	10	11	12			01

Zechariah

Note 6

30

because the bible does not mention any  
 zations for four other kings linking to  
 for each king.  
 t appears unlikely.  
 ing and in anarchy. That is also unlikely.

II Ki 15:8 In the thirty and eighth year of  
 Azariah king of Judah did Zachariah the son of  
 Jeroboam reign over Israel in Samaria six  
 months. II Ki 15:13 Shallum the son of Jabesh  
 began to reign in the nine and thirtieth year of  
 Uzziah king of Judah; and he reigned a full  
 month in Samaria. Note-We count 1 yr for

II Ki 15:17 In the  
 nine and  
 thirtieth year of  
 Azariah king of

Most of the rest of the differences between the Alternate Chronology and our Enhanced Chronology is in the selection of co-regencies. The longest co-regency that we have is a 3.5-year one that is supported by events in the bible. We have a second one of fewer than 2 years in which the king was sick unto death and another minor one of about 2 years. **Our numbers seem to be much more reasonable lengths for co-reigns than the alternate chronology, which has very large co-reigns, some as large as 24 years.**

It's hard to imagine circumstances that would support such long co-reigns as 24 years like the Alternate Chronology has. The Alternate Chronology appears to have selected their co-regencies in order to align their chronology with the Assyrian kings list and it appears that they have gotten most of their ideas from Edwin Thiele's, The Mysterious Numbers of the Hebrew Kings.

There is a book by Dr. Floyd Nolen Jones called “The chronology of the Old Testament. He says that the Assyrian Kings list that David refers to is not reliable and that it was constructed out of many incomplete fragments. He also does not agree with Edwin R. Thiele at all, complaining that he follows archeology ideas and not the scriptures. He chastises the Christian ministers that follow that line of thinking and their teaching of it to their church members. He said that we should not doubt the bible, but the bible is what we should be following.

# **Evidentialism–The Bible and Assyrian Chronology**

by [Larry Pierce](#) on April 1, 2001

Share:

Originally published in Journal of Creation 15, no 2 (April 2001): 62-68.

## **Abstract**

Assyrian chronology is not as simple as Thiele would have us believe, and there is no reason to bend the Bible to fit the current reconstructions of Assyrian chronology.

Ignoring the bible most modern scholars have synchronized the kings list to a solar eclipse that was in 763 BC, and that is the major problem that seems to cause most of the discrepancy. There is an earlier scholar named Jukes Oppert, who synchronized the list to an 809 BC solar eclipse and others after him have picked a 791 BC solar eclipse. **Moving to either earlier solar eclipse would solve the problem and make the Assyrian Kings list agree much better with the bible. We think that the 809 BC solar eclipse is the correct one because that restores 46 of the 50 years that the Alternate Chronology would like to remove. Doing that brings the Assyrian kings list into very close harmony with the bible.**



**The Alternate or New chronology removes 4 years in the reign of Jehoshaphat through a co-regency with his father that we see no need for. He appears to need that extra 4 years to harmonize his list to the Assyrian Kings list and he admits that he does not have any proof in the bible for that 4 year removal.**

**We will cover any other of the time differences in a future discourse where we can get into much more detail.**

Jer 25:11-13 (11 'This whole land will be a desolation and a horror, and these nations will serve the king of Babylon seventy years.

12 'Then it will be when seventy years are completed I will punish the king of Babylon and that nation,' declares the Lord, 'for their iniquity, and the land of the Chaldeans; and I will make it an everlasting desolation. NASU

Jer 29:10 For thus says the Lord: Only when Babylon's seventy years are completed will I visit you, and I will fulfill to you my promise and bring you back to this place. NRSV

Zech 1:7 On the twenty-fourth day of the eleventh month, which is the month Shebat, in the second year of Darius, the word of the Lord came to Zechariah the prophet, the son of Berechiah, the son of Iddo, as follows:

Zech 1:12 Then the angel of the Lord said, "O Lord of hosts, how long will You have no compassion for Jerusalem and the cities of Judah, with which You have been indignant these seventy years?" NASU

Zech 7:1 In the fourth year of King Darius, the word of the Lord came to Zechariah on the fourth day of the ninth month, which is Chislev.

Zech 7:5 "Say to all the people of the land and to the priests, 'When you fasted and mourned in the fifth and seventh months these seventy years, was it actually for Me that you fasted?' NASU

# Timeline of Events

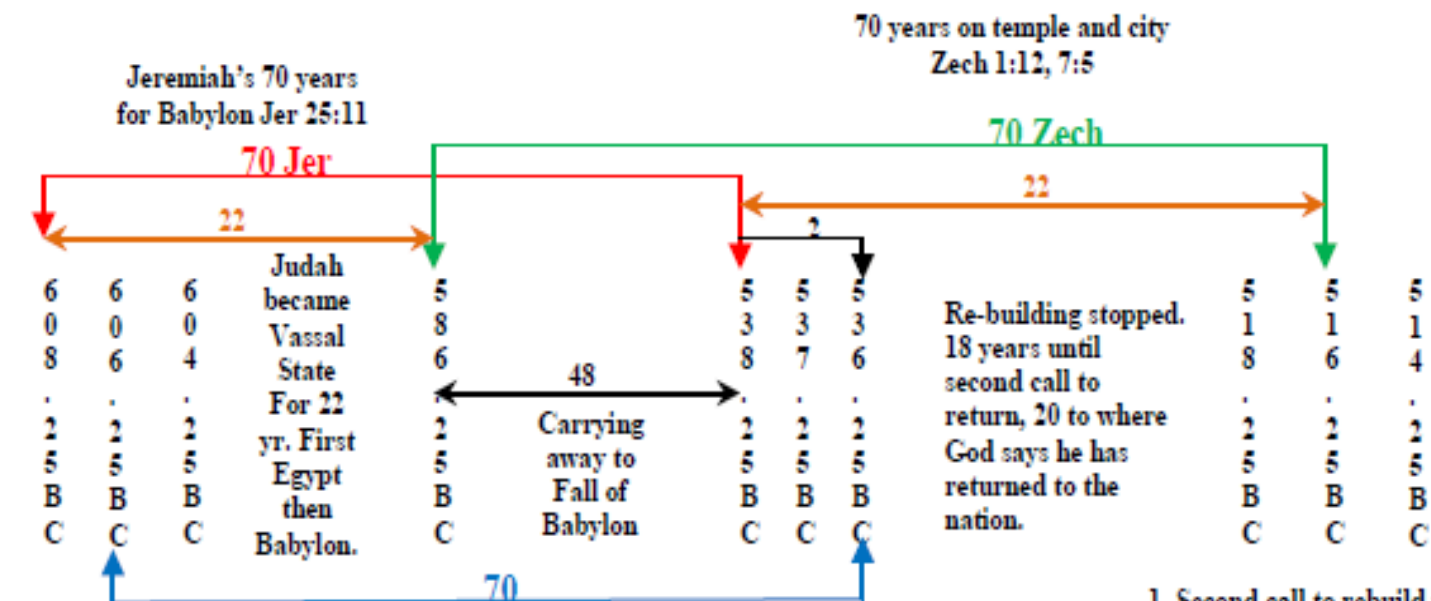

Death Josiah in 609 BC.

Egypt Conquers Judah

Assyrian army defeated by Babylon

Babylon defeated Egypt in 605 BC and then Conquered Judah in third year Dan 1:1

Carrying away to Babylon in 587. Temple and city fall

Babylon Falls 539 Regal Cyrus Decree and return by 537. Re-building stopped after 1 year.

1. Second call to rebuild issued by Darius
2. God has returned to Nation, temple usable.
3. Temple fully completed which was 90 years from 605 BC when Jerusalem was first captured by Nebuchadnezzar at the same time as the Battle of Carchemish.

Nebuchadnezzar began to move against Palestine in 606.25 BC and take land that was promised to Abraham and Lot, 2 years after the fall of Assyria. Seventy years later, which is 1-2 years after the fall of Babylon, the Jews begin to return from Babylon. It's from the first attacks on Israel's Promised Land that we date the 2520 years to Oct 1914. We note that some use 610 BC to 540 BC for the fall of Babylon instead of the 609 to 539 BC dates that we use. We are not sure which set of dates is the actual intended 70 years of Jeremiah since either one is 70 years. The only

more to the fourth year of Darius, and because of that we have a problem, (22 + 70 = 92). This problem and the one in the next section on Jeremiah's 70 years result from trying to make the two different 70-year time periods the same time.

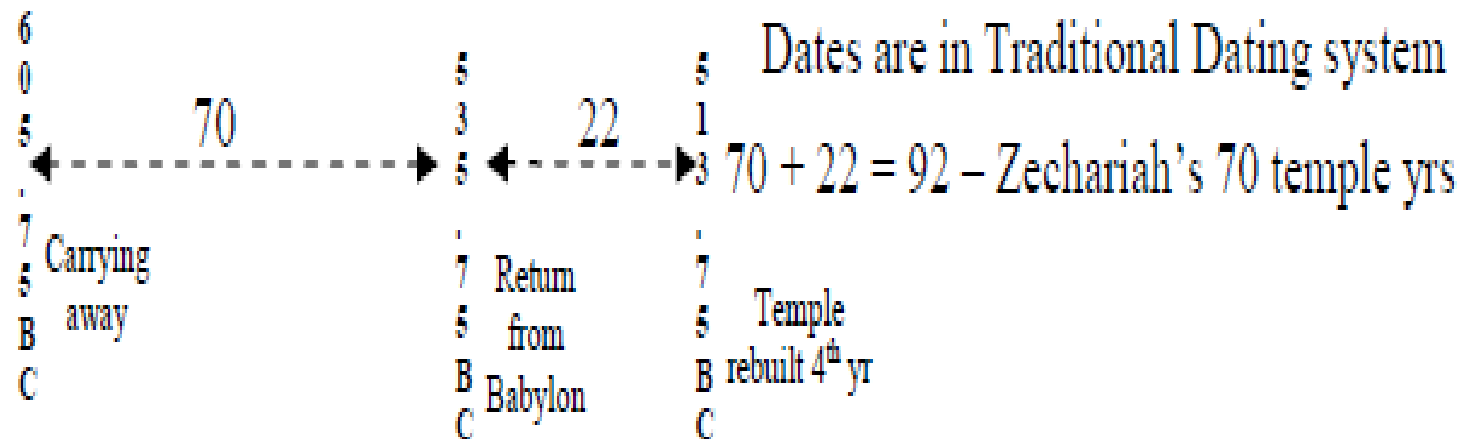

If we are using the Enhanced Chronology that we believe is correct and we only count 50 years from the destruction of the city to the decree of Cyrus, then we get 50 + 20 years which does add

up to the 70 years that Zechariah said that the temple would be rebuilt in 70 years.

Judah began to serve the king of Babylon when Nebuchadnezzar defeated the army of Egypt and Judah then surrendered to him, but the other nations started four years earlier when Assyria fell. The reason for this problem is because of making the two different 70-year time periods the same.

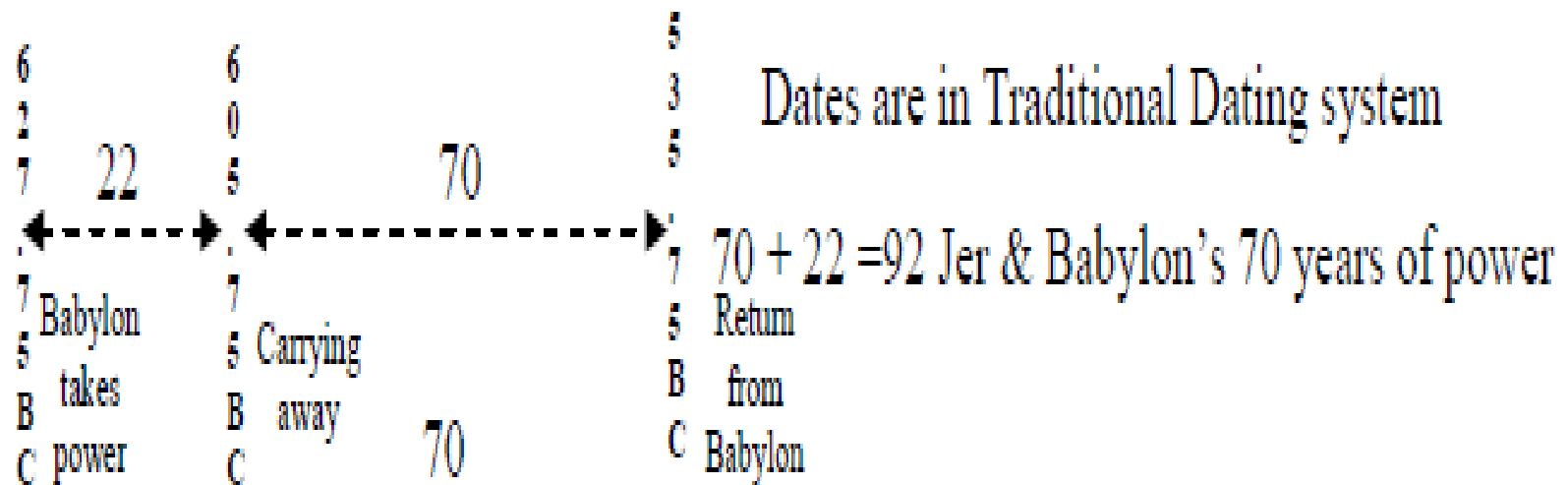

Even if you try to say that the prophecy was not about the nations, but it was only about Judah alone, Judah was under Babylon's control for 18 years before they were carried away. That 18

# Timeline of Events

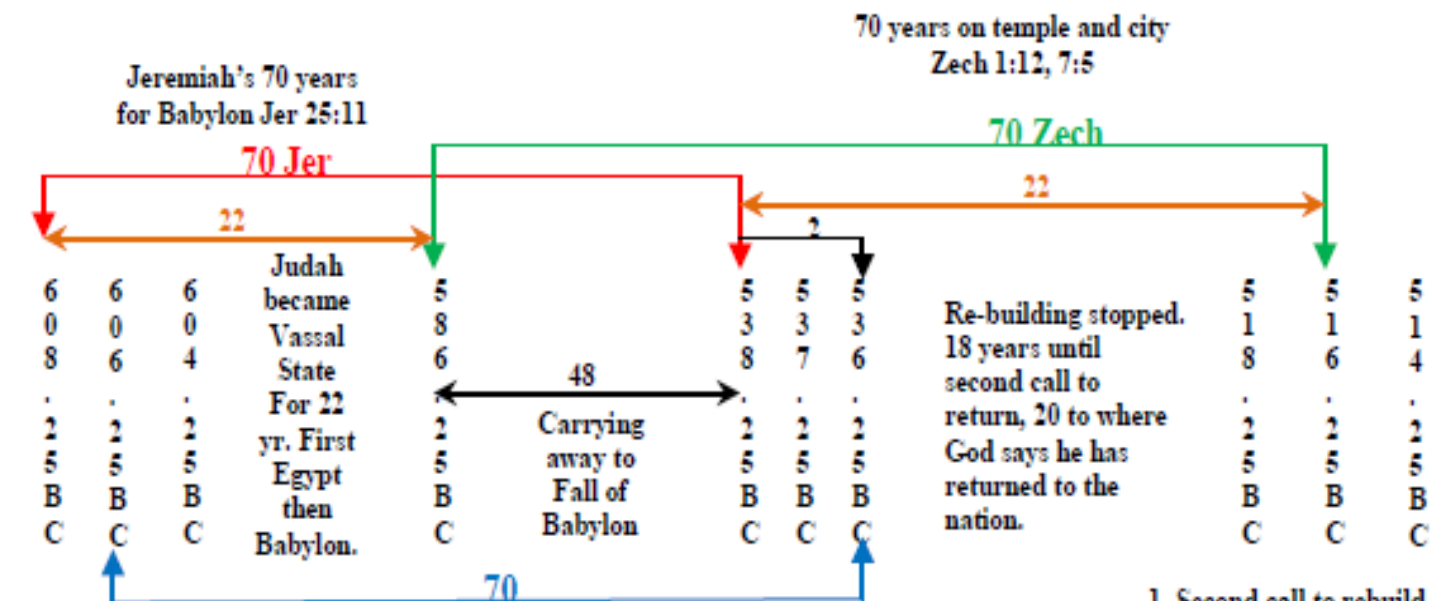

Death Josiah in 609 BC.  
 Egypt Conquers Judah  
 Assyrian army defeated by Babylon

Babylon defeated Egypt in 605 BC and then Conquered Judah in third year Dan 1:1

Carrying away to Babylon in 587. Temple and city fall

Babylon Falls 539 Regal Cyrus Decree and return by 537. Re-building stopped after 1 year.

1. Second call to rebuild issued by Darius
2. God has returned to Nation, temple usable.
3. Temple fully completed which was 90 years from 605 BC when Jerusalem was first captured by Nebuchadnezzar at the same time as the Battle of Carchemish.

Nebuchadnezzar began to move against Palestine in 606.25 BC and take land that was promised to Abraham and Lot, 2 years after the fall of Assyria. Seventy years later, which is 1-2 years after the fall of Babylon, the Jews begin to return from Babylon. It's from the first attacks on Israel's Promised Land that we date the 2520 years to Oct 1914. We note that some use 610 BC to 540 BC for the fall of Babylon instead of the 609 to 539 BC dates that we use. We are not sure which set of dates is the actual intended 70 years of Jeremiah since either one is 70 years. The only

*June)14 both Nabopolassar and Crown Prince Nebuchadnezzar campaigned in a mountainous region not identifiable from the text.15 Nabopolassar, however, returned to Babylon the next month, whereas Nebuchadnezzar stayed on until sometime during the sixth month (1 Aug.-30 Aug.). 16 A month or two later (29 Sept.-28 Oct.) ~~Nabopolassar~~-Nebuchadnezzar set out with his army for Kimubu, a strategic city south of Carchemish, 17 **and was able to capture it near the end of 607 (27 Nov.-26 Dec.)**, also leaving a garrison there before going home in early 606 (25 Jan.-23 Feb.).18 In the spring or early summer of the same year, the Egyptians laid siege to Kimubu for four months and eventually recaptured it. The Babylonian World- Gwendolyn Leick University of Chicago Oriental Institute. Pages 181-182 From tablet, **BM 22047** (96-4-9, 152)*



Part of the problem regarding our understanding of this time area, is that **we need to be looking at the total promised land of Israel**, which included the land of the ten tribes and not just the land of Judah. The promised land of the ten tribes was part of the area that Nebuchadnezzar was attacking in his conquering of that area, and that is why the date of 607 BC is where the 2520 starts from. In order to get to Kimubu Nebuchadnezzar had to of crossed over the Euphrates river and when he did that he was taking land that had been promised to Abraham's offspring. That is why the 607 BC date started counting the 2520 years from that point in time. The ten tribes were originally a part of Israel until they were carried away by Assyria and for that reason we should be looking at that area of land as well, since it still belonged to Israel because of the promise to Abraham. In addition both the ten and two tribes are prophesied to come back.

49 year Jubilee Cycles?  
If not what are they?

50 x 50 = 2500 Chronology Locked

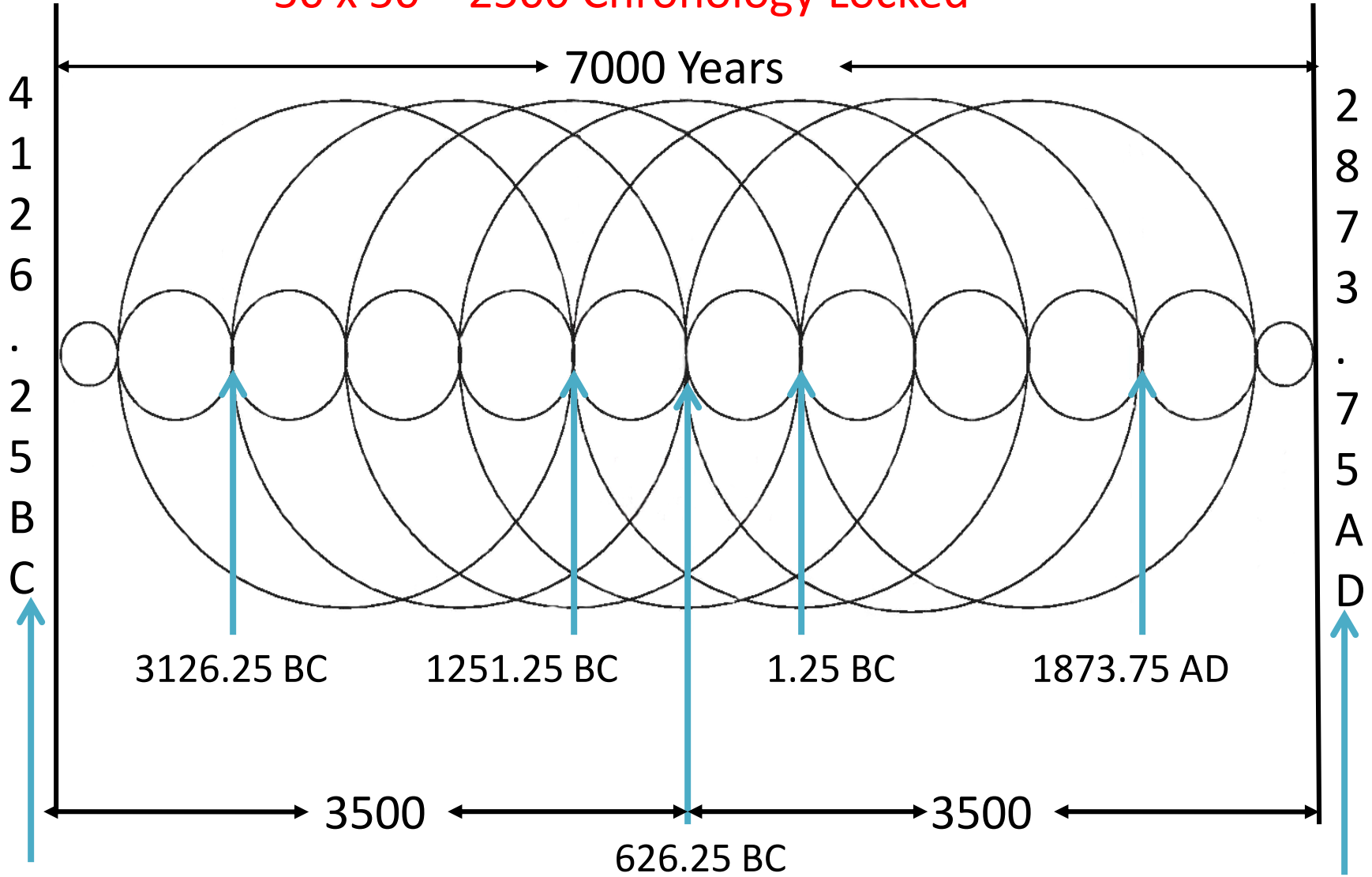

Wrath

Seven Important Dates

Mercy

The date shown at the arrow on this diagram is the date at the start of the 40th year after Exodus, which is 19 Jubilee before the midst of the year Jubilee pattern. In the Second Vol Jubilee, Israel first took land during the 40th yr 1576.25-1575.25 BC on the East side, Duet chap 2. The Second Volume Jubilee count begins at the close of the 40th yr after the land is captured (1575.25 BC), so we are left with a 1 yr offset at the center point. Both patterns are valid and they support the Jubilee as discussed on the next page.

The Jubilee system on this diagram is the 25 inch tabernacle one which is centered on the midst of the years. These dates are the start of the Jubilee year and not the close.

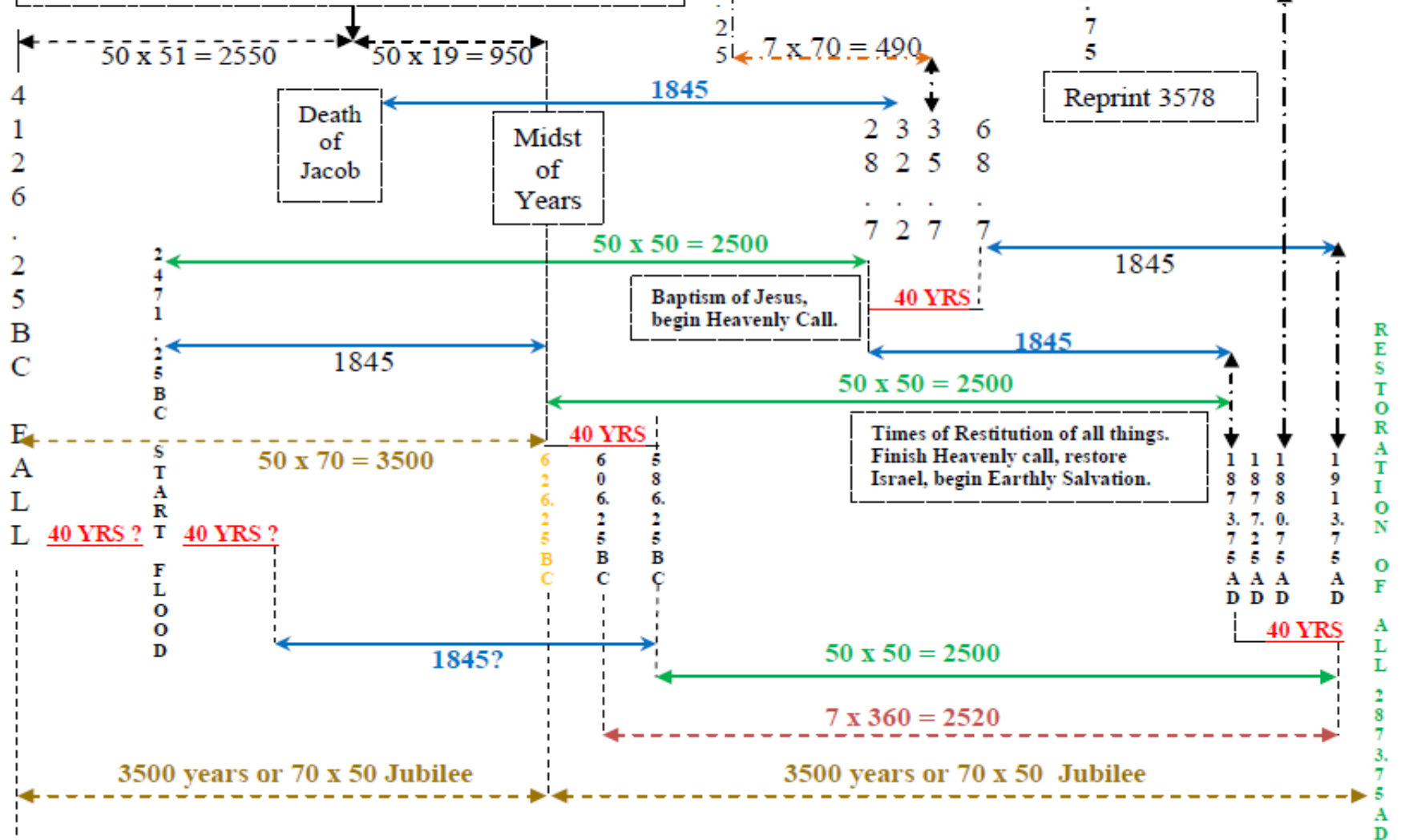

# 49s & 50 x 50 Related to the Nation of Israel

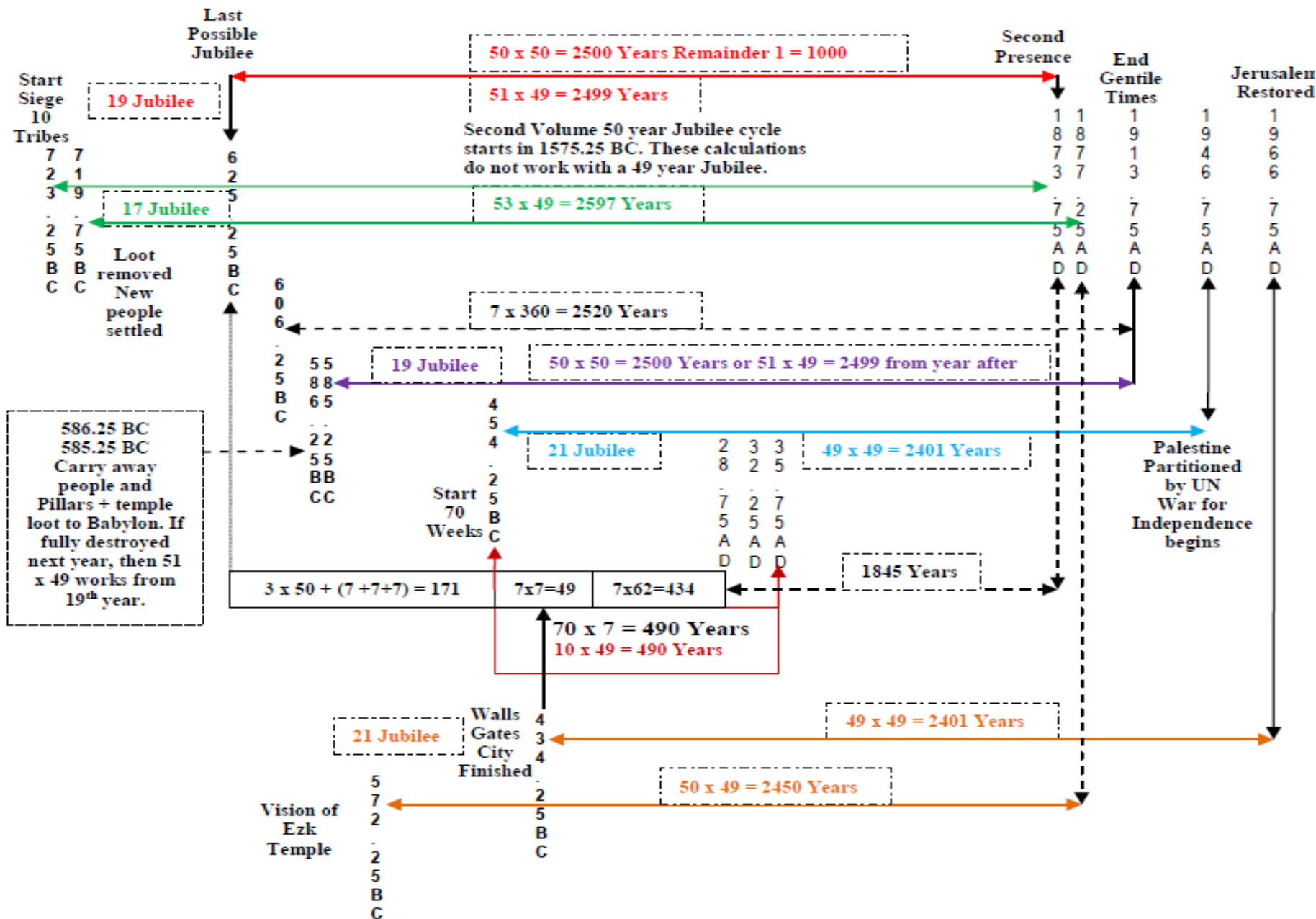

## **7<sup>1</sup> Times 360-Dan 4:25, 29**

$7 \times 62 = 483$  ---- Dan chapter 9.

$7 \times 360$ ---- **This set of calculations is the same principle as the 2520 of the Second Volume, and it is also the same as the first 7x of Lev chapter 26**

$-721.25 + (7 \times 360) = 1798.75$  AD-----Ten tribe destruction—feet of image struck!

$-606.25 + (7 \times 360) = 1913.75$  AD-----Date Neb crossing into 10 tribes—full image struck!

$-572.25 + (7 \times 360) = 1947.75$  AD----- Vision of Ezekiel temple --Israel declared a nation.

$-553.75 + (7 \times 360) = 1966.75$  AD----- Vision of 2300 Mornings & Evenings --Jerusalem restored.

## **7<sup>2</sup> Times**

$7 \times 7 = 49$ ----**From  $7 \times 7$  of Daniel 9:25, which is the hint “key” to “all” of the calculations.**

$-454.25 + (7 \times 7) = 405.25$  BC---Jerusalem destroyed in 586.25 BC, not rebuilt until this 49 yrs.

$-454.25 + (7 \times 7 \times 10)$ ---- Start 490--35.75 AD End Jewish favor, Gentiles grafted into the promise.

$-723.25 + (7 \times 7 \times 53) = 1873.75$  AD---Begin siege of 10 tribes to second presence.

$-719.75 + (7 \times 7 \times 53) = 1877.25$  AD---Land settled by Assyrians, to land able to be owned by Jews.

$-572.75 + (7 \times 7 \times 50) = 1877.25$  AD—Vision of temple to able to be owned by Jews.

$-625.25 + (7 \times 7 \times 51) = 1873.75$  AD—Last possible Jubilee by Judah to second presence.

$-585.25 + (7 \times 7 \times 51) = 1913.75$  AD---From destruction until second blow on image. The city & temple really were finished being destroyed in the 19<sup>th</sup> year as it says in Jer 52:12. It was taken in the 18<sup>th</sup> year but broken down and burned by the 19<sup>th</sup> year. See the explanation and diagram in the chapter about the 49-year cycles.

## **7<sup>3</sup> Time to Fourth & Last Beast**

$7 \times 7 \times 7 = 343$  or  $7 \times 49$ ---- **The method for this one is from the  $7 \times 7 \times 7$  of Lev chapter 26.**

$-454.25$  BC + 49 = 405.25 BC From Daniel chapter 9 and  $7 \times 7$ . Jerusalem restored during 49

$-405.25$  BC +  $(7 \times 7 \times 7) = 62.25$  BC, which is the date that the Roman General Pompey won the siege and took control of Jerusalem. In other words, this is the date of the fourth and most terrible beast of Daniel’s vision taking control of Judah, and it measures the time from the  $7 \times 7$  of Daniel until the fourth beast of Rome. The four beasts of Daniel are the wild beasts of the prophecy.

## **7<sup>4</sup> Time to Return to Nation & Jerusalem**

$7 \times 7 \times 7 \times 7 = 2401$  or  $49 \times 49$ ---- **The method for this one is from the  $7 \times 7 \times 7 \times 7$  of Lev chapter 26.**

**It is the square of the  $7 \times 7$  of Daniel which shows that it relates to the second restoration.**

$-454.25 + (7 \times 7 \times 7 \times 7) = 1946.75$  AD---Start of 70 weeks to Partition of Palestine by UN.

$-434.25 + (7 \times 7 \times 7 \times 7) = 1966.75$  AD---Restoration of Jerusalem in time of Medes & Persians

# DIAGRAM "C"

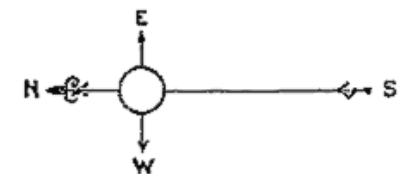

ALPHA DRAGONIS

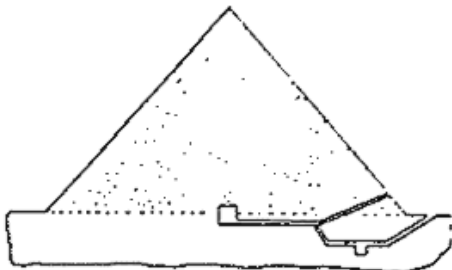
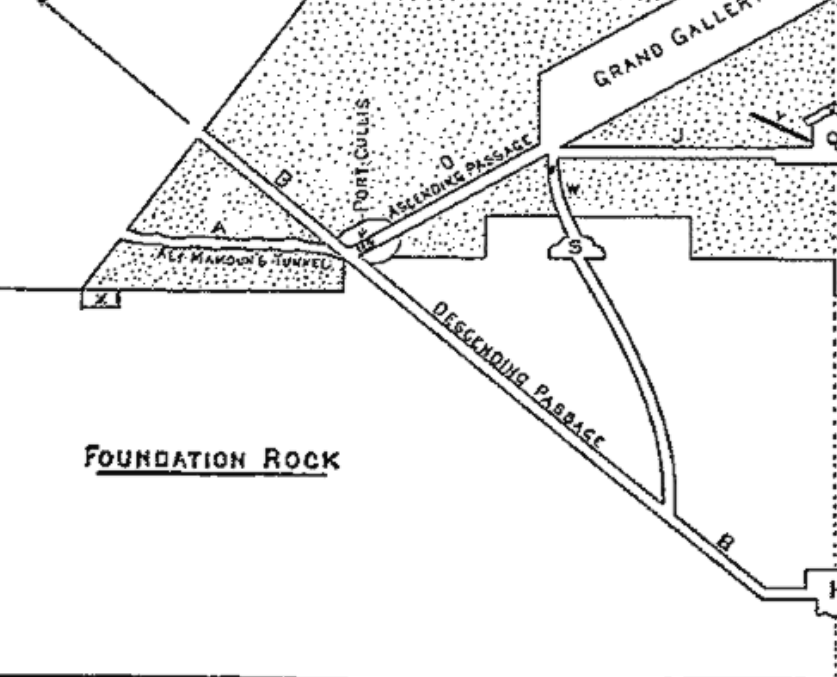

SECOND PYRAMID

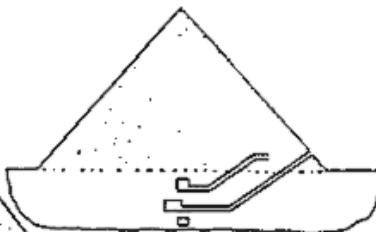

THIRD PYRAMID

VERTICAL SECTION  
OF THE GREAT PYRAMID  
(LOOKING EAST)

NOT DRAWN TO A SCALE

